

Technical data

GP 100-2 EPDM with C 36

Normally closed safety edge SL NC II consisting of sensor and aluminium profile from the profile range C 36.

Testing basis	
ISO 13856-2	
Switching characteristics at $v_{\text{test}} = 200 \text{ mm/s}$	
Switching operations	>10,000
Actuation force	
Test piece (cylinder) Ø 80 mm	< 150 N
Actuation distance	
Test piece (cylinder) Ø 80 mm	17 mm
Actuation angle	
Test piece (cylinder) Ø 80 mm	90°
Response time	82 ms
Finger detection	no
Safety classifications	
ISO 13856: Reset function	without
ISO 13849-1:2015	Category 3 PL d
B_{10D} (Sensor)	2×10^6
Mechanical operating conditions	
Sensor length (min./max.)	30 cm / 6 m
Cable length (min./max.)	1.5 m / 100 m
Bend radii	not possible
Operating speed	
(min. / max.)	10 mm/s / 200 mm/s
max. load capacity	600 N
IEC 60529: Degree of protection	IP67
Humidity (max. at 23 °C)	95 % (non-condensing)
Operating temperature	-10 to +55 °C
Storage temperature	-20 to +80 °C
Weight	2.1 kg/m
Electrical operating conditions	
Contact transition resistance (max.)	5 Ohm
Number of sensors type BK	max. 10 in series
Switching voltage (PELV) (max.)	48 V DC
	48 V AC 50/60 Hz
Protection class	III
Switching current (max.)	20 mA
Contact fuse protection, external	250 mA slow-acting
Connection cable	Ø 3.3 mm PVC 1x 0.5 mm ²

Dimensions and distances

GP 100-2 EPDM (1:3)

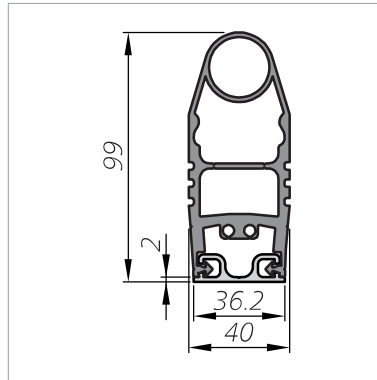

Dimensional tolerances according to ISO 3302 E2/L2.

Test conditions

according to ISO 13856-2

- Installation position B
- Temperature +20 °C
- Measurement point c3
- Test sample 1 with Ø 80 mm
- without control unit

All data stated here is documented in EC design type test certificates.

Force-distance ratios

Actuation force	73 N
Response time	1410 ms
Actuation distance (A)	14.1 mm
Overtravel distance	
up to 250 N (B1)	34.3 mm
up to 400 N (B2)	37.5 mm
up to 600 N (C)	41.1 mm
Total deformation	55.2 mm

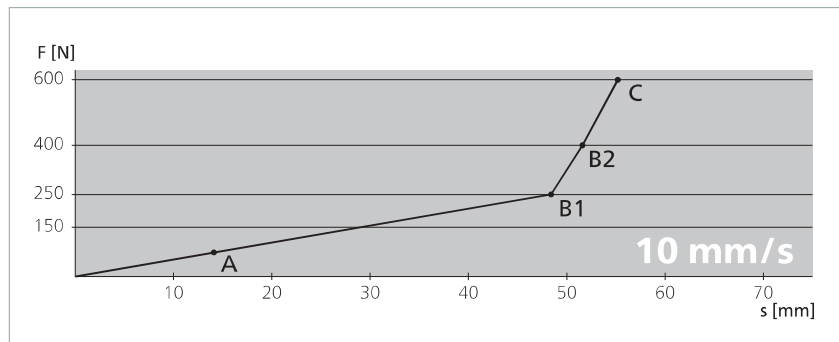

Actuation force	56 N
Response time	76 ms
Actuation distance (A)	7.6 mm
Overtravel distance	
up to 250 N (B1)	36.8 mm
up to 400 N (B2)	40.4 mm
up to 600 N (C)	43.7 mm
Total deformation	51.3 mm

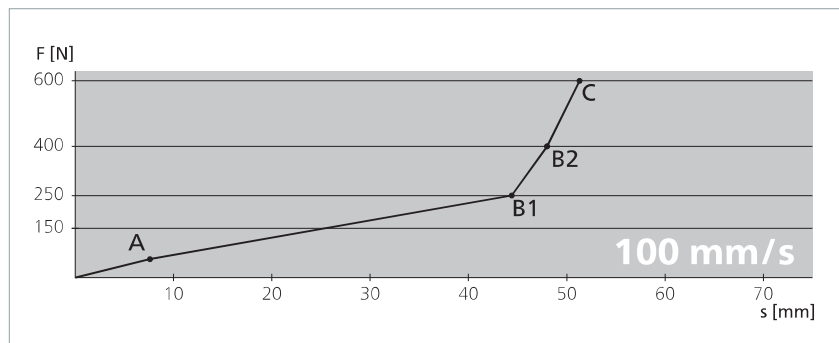

Actuation force	68 N
Response time	82 ms
Actuation distance (A)	16.4 mm
Overtravel distance	
up to 250 N (B1)	29.4 mm
up to 400 N (B2)	32.8 mm
up to 600 N (C)	35.7 mm
Total deformation	52.1 mm

